

# MULTITEL



## HX 200



- Commandes hydrauliques proportionnelles avec la possibilité de réglage de la vitesse de tous les mouvements, aussi bien du sol que de la nacelle.
- Parallélogramme hydraulique de maintien à niveau nacelle.
- Sortie hydraulique des deux éléments télescopiques du bras.
- Chemins de câbles internes au bras.
- Clapets de blocage sur tous les mouvements.
- Pompe manuelle pour manoeuvre d'urgence.
- Arrêt coup de poing en cas de panne.
- Démarrage et arrêt du moteur depuis la nacelle.



- Proportional hydraulic controls from both control posts.
- Hydraulic cage levelling.
- Synchronous multi-stage telescope cylinders.
- Internal hose and cable ducts.
- Hydraulic check valves on all movements.
- Emergency hand pump.
- Emergency stop on both control stations.
- Engine start-stop on both control stations.



- Hydraulische Proportionalsteuerung mit Geschwindigkeitsregelung für alle Funktionen, von Korb- und Bodenbedienung.
- Hydraulische Korbnivellierung.
- Synchron-ausführende Mehrstufen Teleskop-Zylinder.
- Innenliegende Kabel- und Schlauchverlegung.
- Hydraulische Sperrventile auf jede Bewegung.
- Not-Handpumpe.
- Not-Stop an beide Steuerpulte.
- Fahrzeug Start-Stop an beide Steuerpulte.



- Comando idraulico proporzionale con regolazione della velocità di tutti i movimenti sia dal cestello che da terra.
- Parallelismo idrostatico del cestello.
- Uscita oleodinamica degli sfili telescopici del braccio.
- Tubi e cavi installati all'interno del braccio.
- Valvole di blocco su ogni movimento.
- Pompa a mano di emergenza.
- Pulsante di arresto in caso di avaria.
- Avviamento e arresto del motore dal cestello.

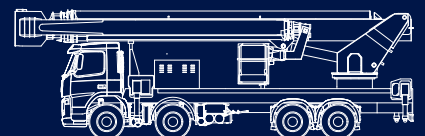
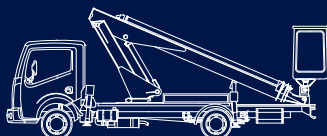



# HX200

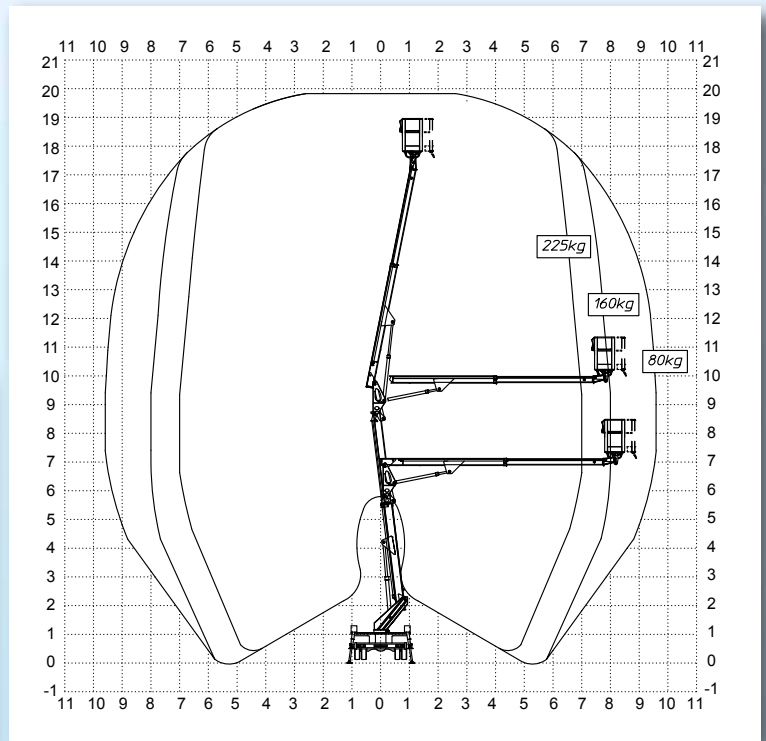
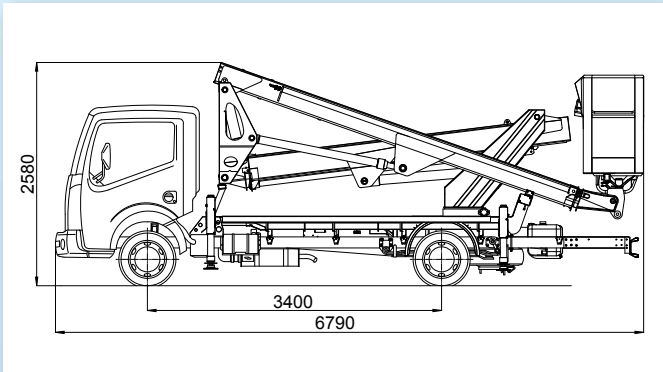

Hauteur de travail env.	Max working height	Maximale Arbeitshöhe	Altezza max di lavoro	<b>19,80 m</b>
Hauteur plancher nacelle env.	Maximum platform height	Maximale Plattformhöhe	Altezza piano calpestio cestello	<b>17,80 m</b>
Déport maxi de travail env.	Max working outreach	Maximale seitliche Reichweite	Sbraccio max di lavoro	<b>7,00 m (225kg) - 9,60 m (80kg)</b>
Rotation de la tourelle	Turret rotation	Schwenkbereich	Rotazione torretta	<b>360°</b>
Rotation de la nacelle	Cage rotation	Hydraulische Korbdrehung	Rotazione idraulica del cestello	<b>65°+ 65°</b>
Sortie télescopique des bras.env	Boom telescopic amplitude	Teleskopausschub	Escursione telescopica dei bracci	<b>6,21 m</b>
Dimensions maxi nacelle	Max cage dimensions	Max Arbeitskorbabmessungen	Dimensioni max del cestello	<b>1,40 x 0,70 x 1,10 m</b>
Charge utile en nacelle	Safe working load on cage	Tragfähigkeit	Portata cestello	<b>225 kg</b>
Dévers maxi admissible	Max admissible slope	Maximale zulässige Neigung	Pendenza ammissibile	<b>1°</b>